

[544] BigQuery ML and Cost Management

Tyler Caraza-Harter

Outline

BigQuery ML Basics

Feature Transformation

Cost Management

Train/Test Split

BigQuery provides a `DATA_SPLIT_METHOD` config, but its a bit unusual.

Default behavior depends on dataset

- <500 rows: 100% training data
- <50K rows: 80% training data
- bigger: 10K rows for test, rest for training

Documentation: "When there is a data split, you can find the temporary split results (Training Data, Evaluation Data) on the Model Details page in the BigQuery Console and the model API `data_split_result` field. **These split tables will be saved for 48 hours.** If you will need them for longer than 48 hours, copy them out of the anonymous dataset for longer retention."

Recommendation:

- split manually using `rand() < ratio` in SQL (`rand` gives num between 0 and 1)
- disable BigQuery splitting: `DATA_SPLIT_METHOD="NO_SPLIT"`

Training

Step 1: write a query to select both features and label

```
SELECT yesterday_temp, humidity, temp
FROM weather
```

features label
(to predict)

Training

Step 2: choose a model name and create it

```
CREATE OR REPLACE MODEL myproj.mydataset.mymodel  
OPTIONS (...)  
name
```

AS

```
SELECT yesterday_temp, humidity, temp  
FROM weather
```

hierarchy
projects
 datasets
 tables
 models

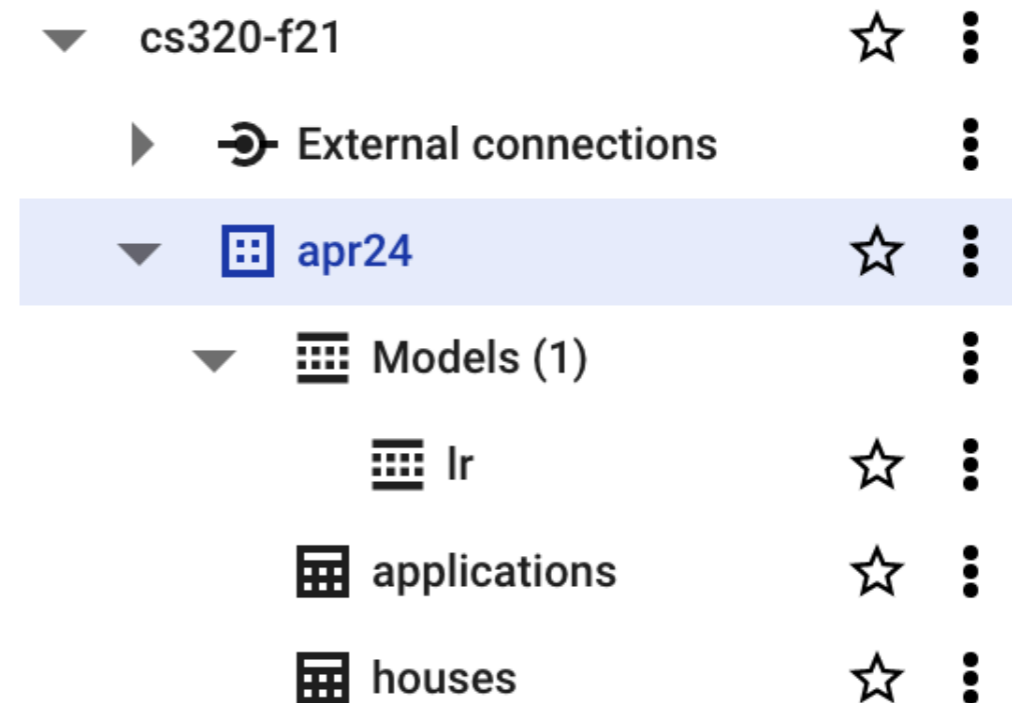

Training

Step 3: choose type of model

```
CREATE OR REPLACE MODEL myproj.mydataset.mymodel  
OPTIONS (MODEL_TYPE='LINEAR_REG')
```

AS

```
SELECT yesterday_temp, humidity, temp  
FROM weather
```

Options: LINEAR_REG, LOGISTIC_REG, KMEANS, MATRIX_FACTORIZATION, PCA, AUTOENCODER, AUTOML_CLASSIFIER, AUTOML_REGRESSOR, BOOSTED_TREE_CLASSIFIER, BOOSTED_TREE_REGRESSOR, RANDOM_FOREST_CLASSIFIER, RANDOM_FOREST_REGRESSOR, DNN_CLASSIFIER, DNN_REGRESSOR, DNN_LINEAR_COMBINED_CLASSIFIER, DNN_LINEAR_COMBINED_REGRESSOR, ARIMA_PLUS, ARIMA_PLUS_XREG, TENSORFLOW, TENSORFLOW_LITE, ONNX, XGBOOST

Training

Step 4: indicate label column (others are assumed features)

```
CREATE OR REPLACE MODEL myproj.mydataset.mymodel  
OPTIONS (MODEL_TYPE='LINEAR_REG',  
        INPUT_LABEL_COLS=['temp'])
```

AS

```
SELECT yesterday_temp, humidity, temp  
FROM weather
```



Using Trained Models

Each of these functions return a table related to a model.

what are the coefficients used to multiply features?

ML.WEIGHTS(MODEL ????)

what are the predictions given the features?

ML.PREDICT(MODEL ????, (????))

SQL query to get features



how well do we predict (various metrics) given the features+label?

ML.PREDICT(MODEL ????, (????))

SQL query to get features and label



Using Trained Models

Each of these functions return a table related to a model.

what are the coefficients used to multiply features?

ML.WEIGHTS(MODEL ????)

example:

```
SELECT *  
FROM ML.WEIGHTS(MODEL ????)
```

TopHat, Demos

Outline

BigQuery ML Basics

Feature Transformation

Cost Management

Patterns

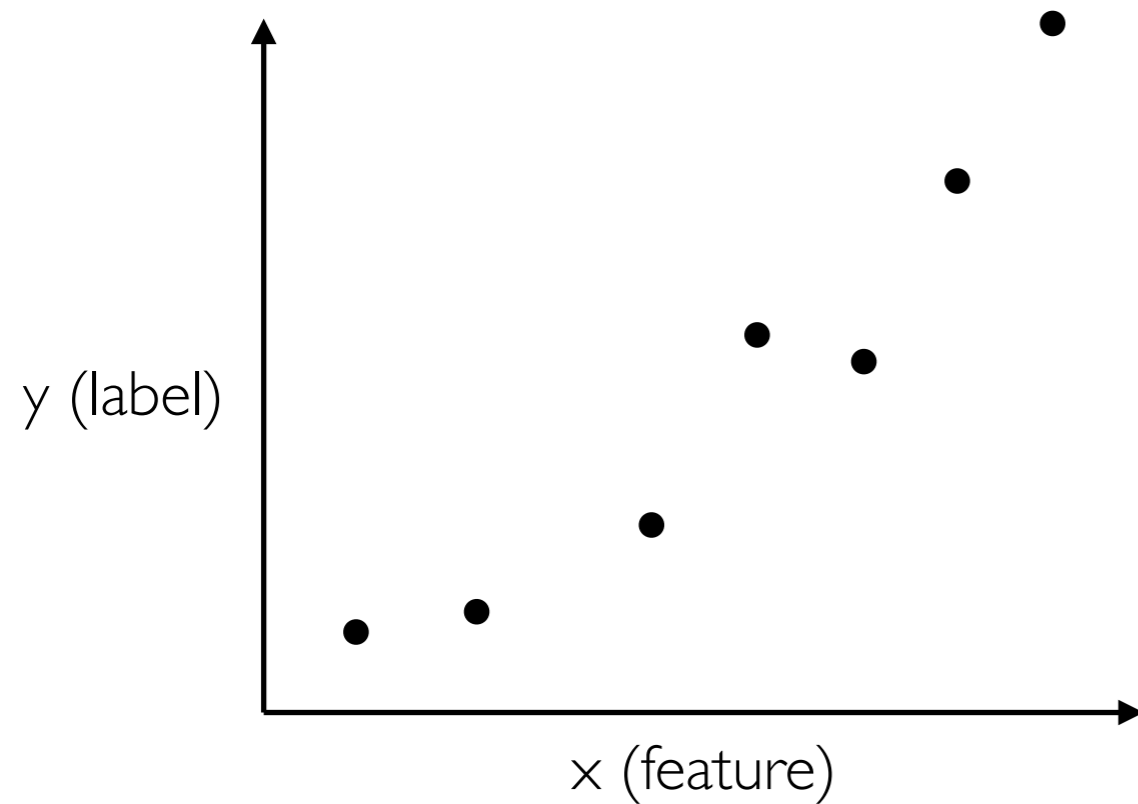

non-linear patterns

- some models (e.g., DNNs) naturally handle this
- others (e.g., LinearRegression) do not

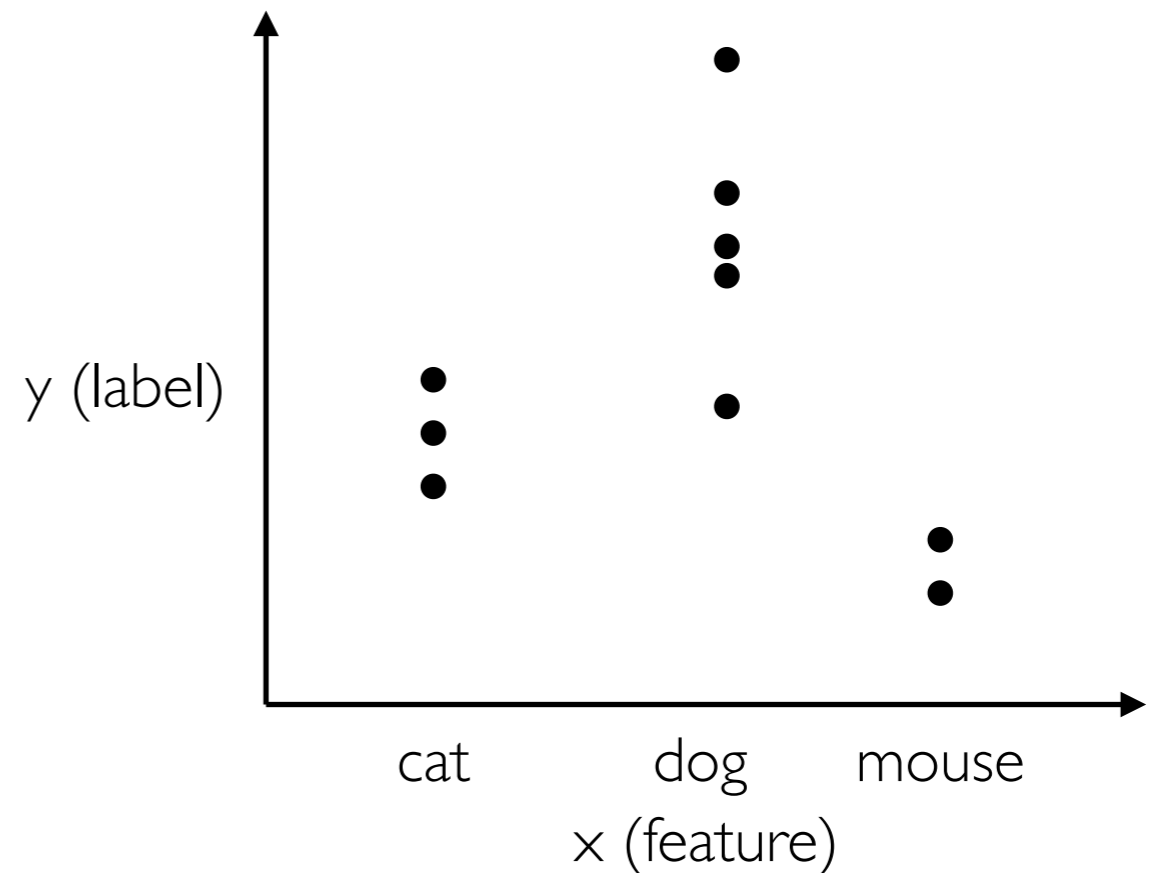

categorical features

- some models (e.g., DTs) naturally handle this
- others (e.g., LinearRegression) do not

Feature Transformation

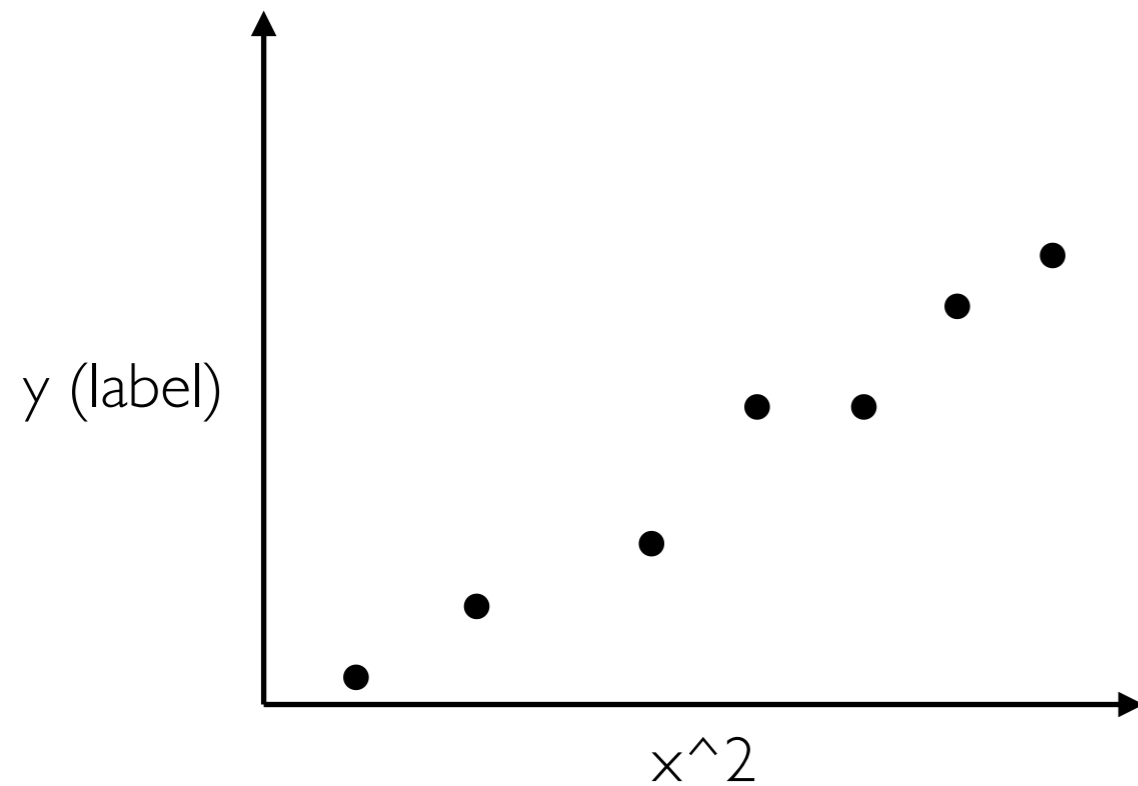

non-linear patterns

- can introduce new features than are computed as functions of originals (e.g., $x_2 = x^2$)
- a linear model over the new features corresponds to a non-linear model over the originals

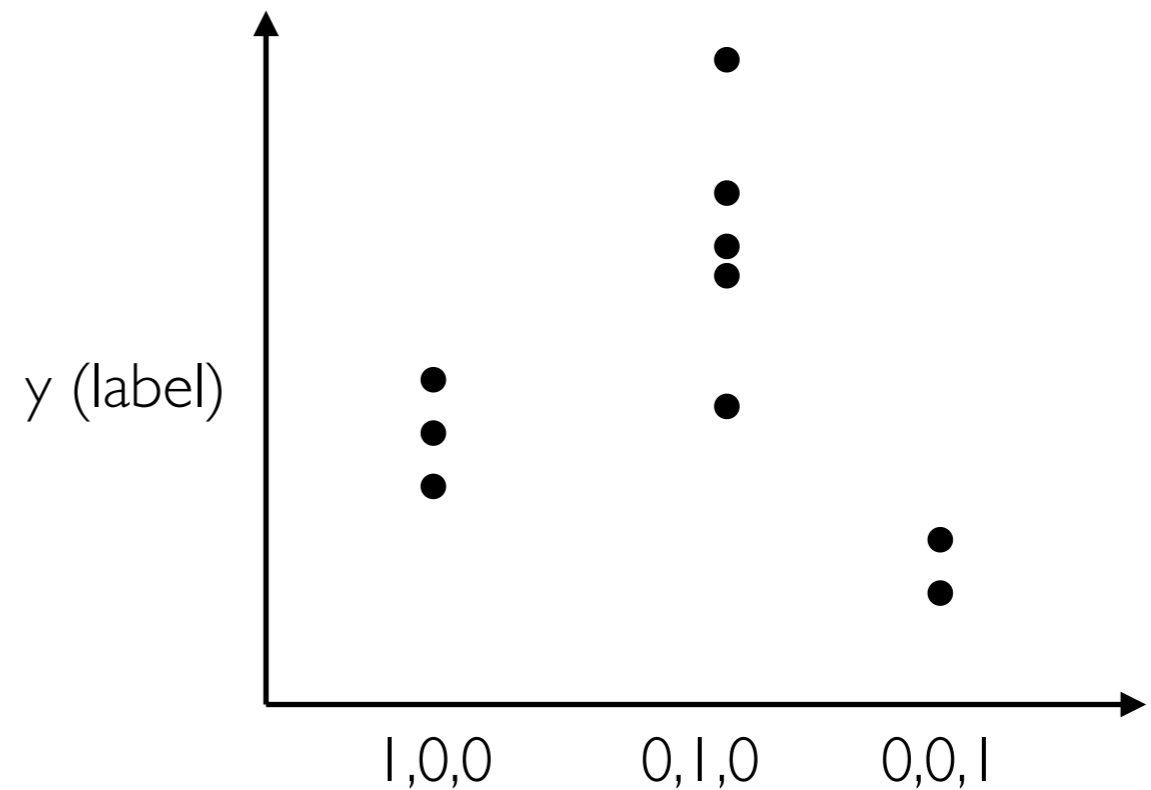

categorical features

- encode categorical features as numbers (e.g., as matrix of zeros and ones for OneHot encoding)

Demos

Outline

BigQuery ML Basics

Feature Transformation

Cost Management

Internal Design

other regions...

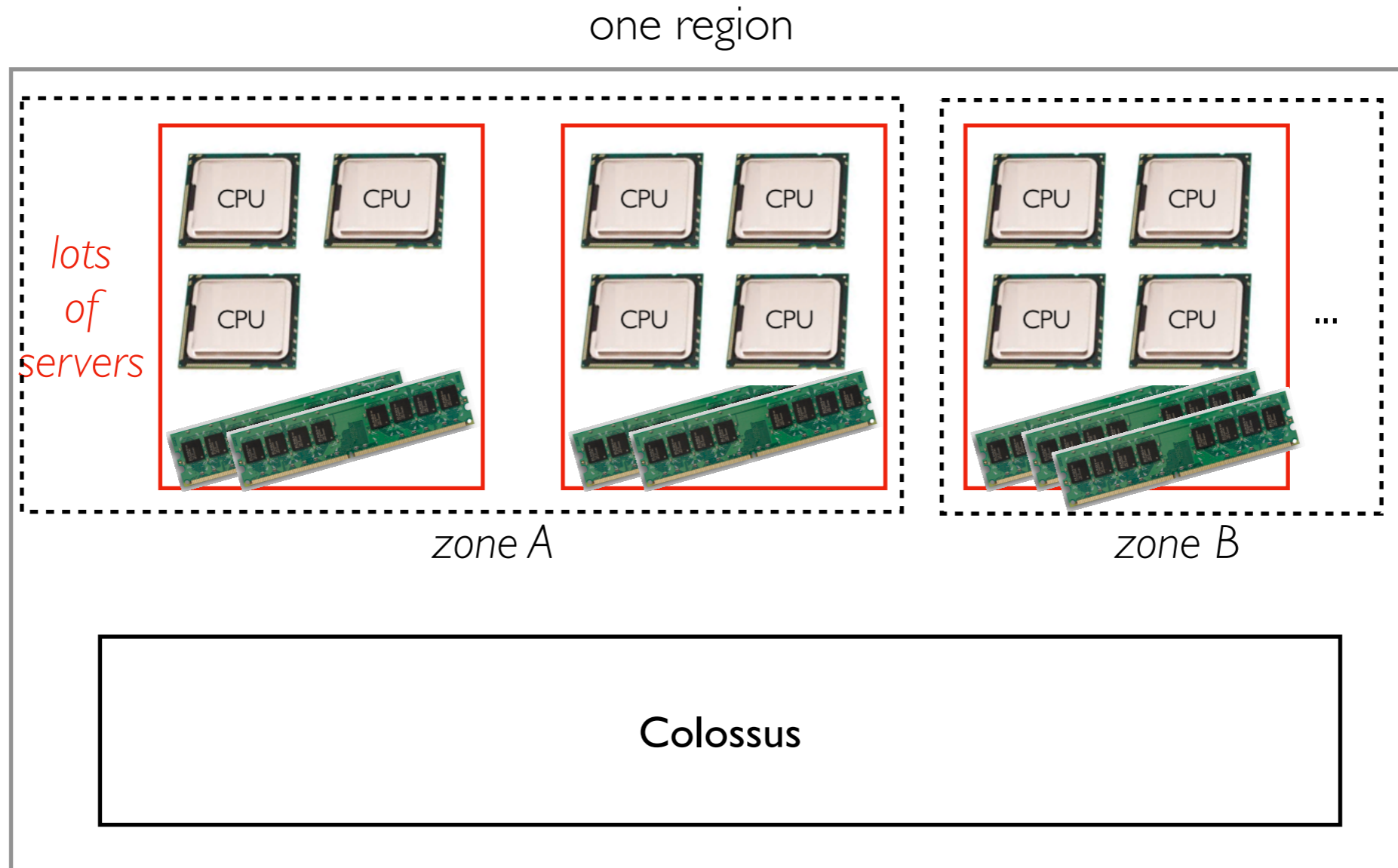

- **Query engine:** Dremel running on many servers with lots of CPU+RAM
- **Storage engine:** Capacitor files in Colossus file system
(not clear if Dremel+Colossus servers are co-located on same machines)

Internal Design

other regions...

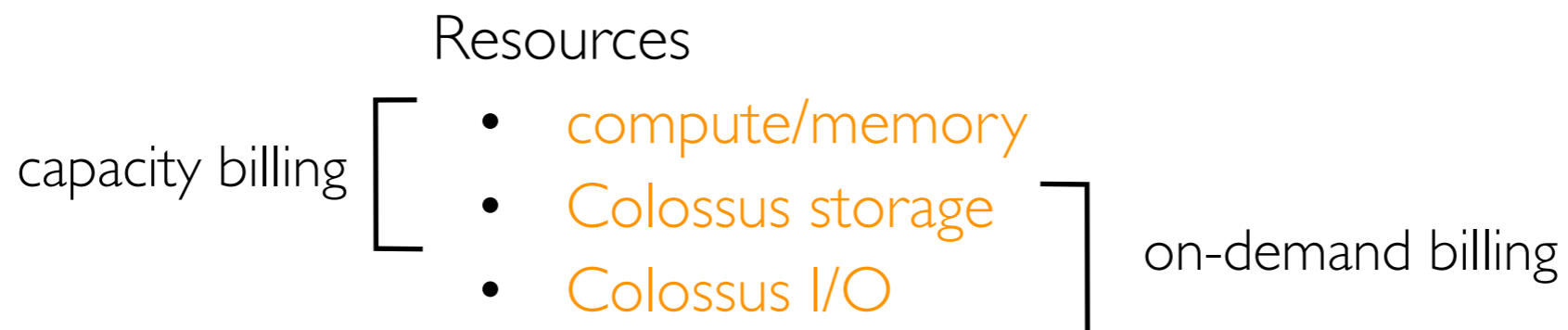
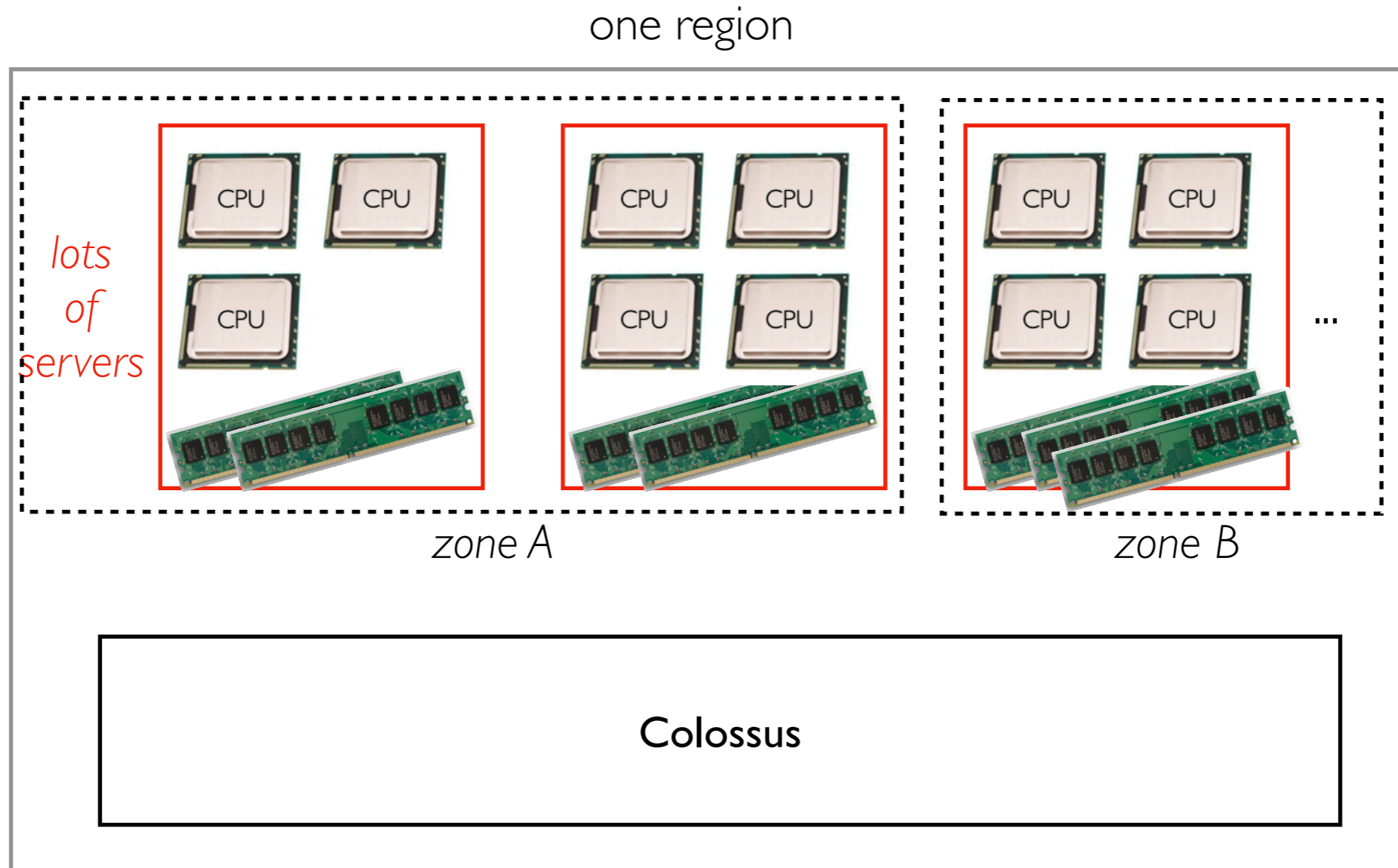

BigQuery Slots

other regions...

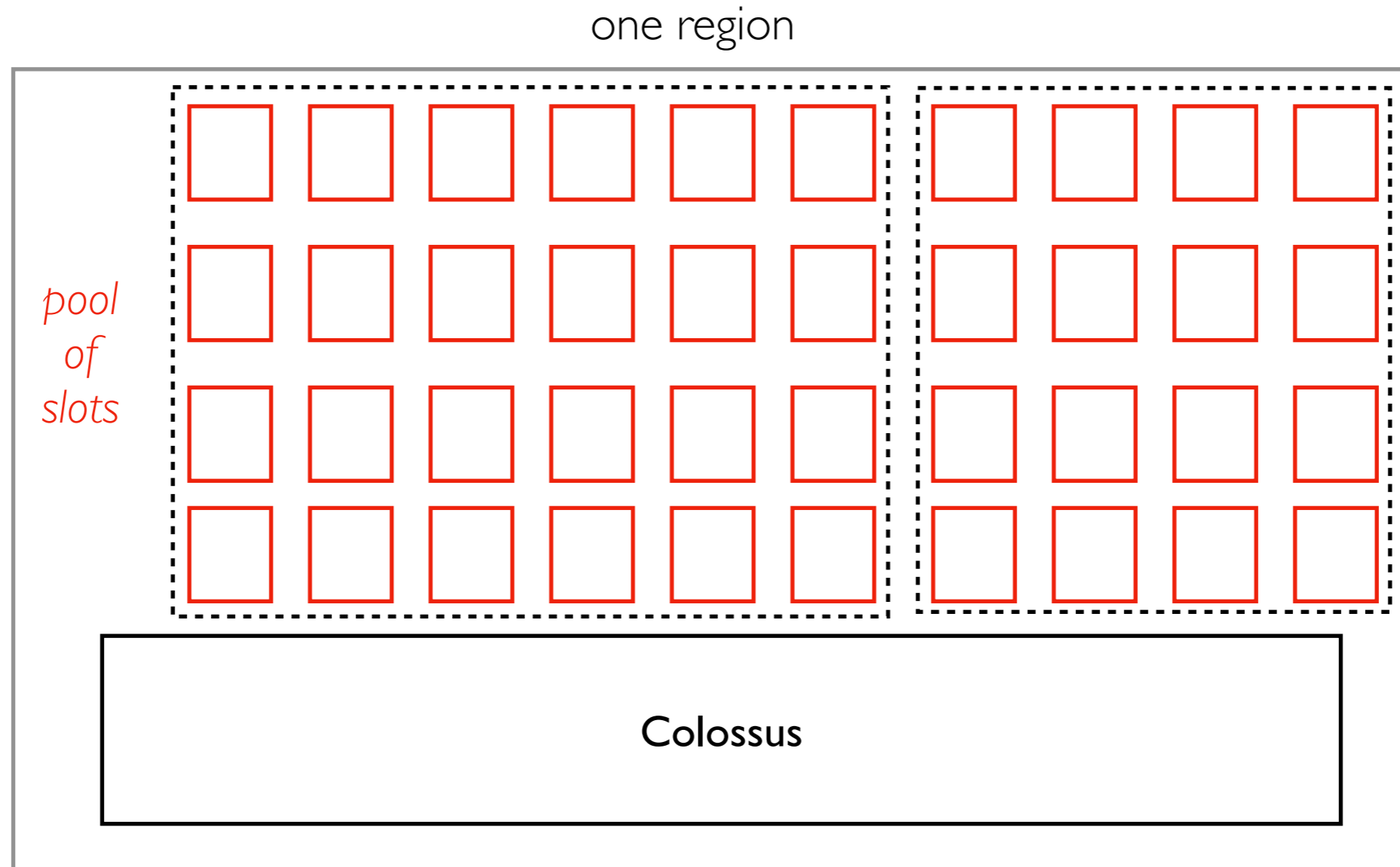

- the compute and memory resources of the servers are broken down into a pool of "slots"
- a slot has approximately $\frac{1}{2}$ cores and 1 GB of RAM
- if newer servers get added with faster CPUs or different core/memory ratios, the exact resources can change a bit

Billing Model 1: Capacity Pricing (compute based)

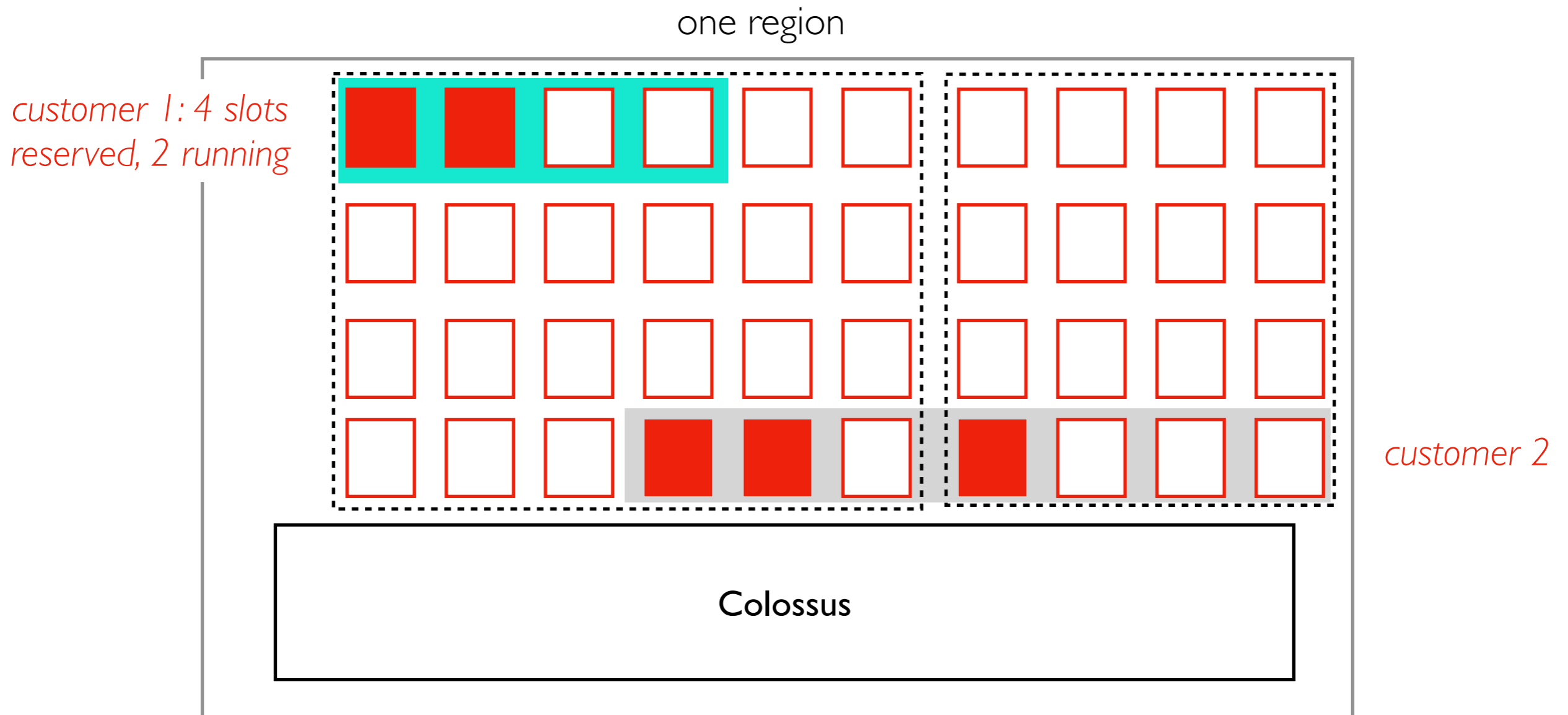

- customers can pay a fixed rate for slot capacity (about \$0.96 for 1 slot day)
- whether or not they use the slot does not affect the cost
- reservations aren't fixed to one location (execution will ideally happen near the data).
- *slightly more expensive than the e2-medium instances we used this semester, which have 2x compute and 4x memory resources (but not complementary I/O to Colossus). But VMs are IaaS and BigQuery is PaaS.*

Billing Model 1: Capacity Pricing (compute based)

one region

customer 1: 4 slots reserved, 2 running

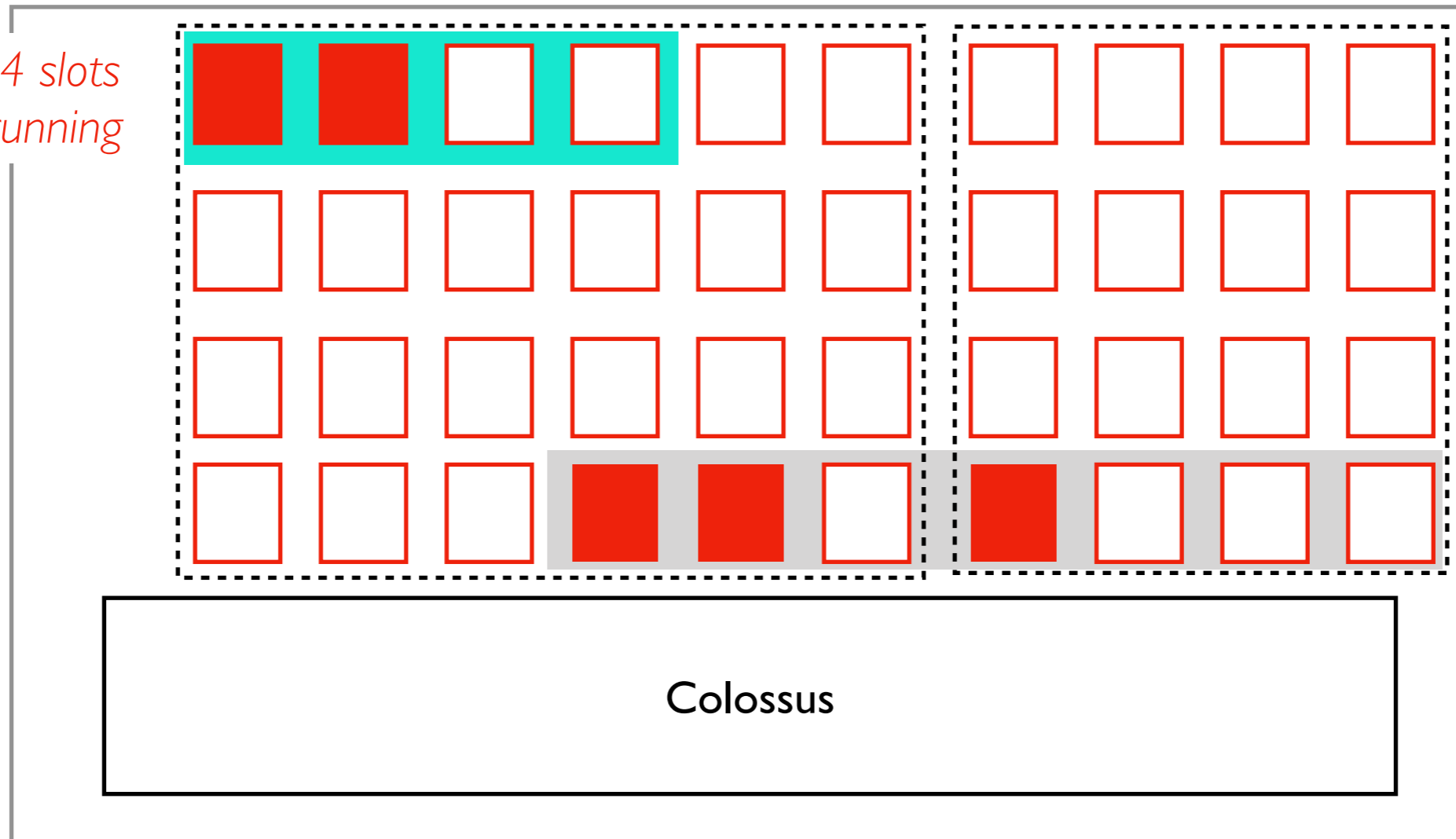

customer 2

Excess capacity cases:

- not reserved
- reserved, but not currently used

Billing Model 2: On-Demand Pricing (I/O based)

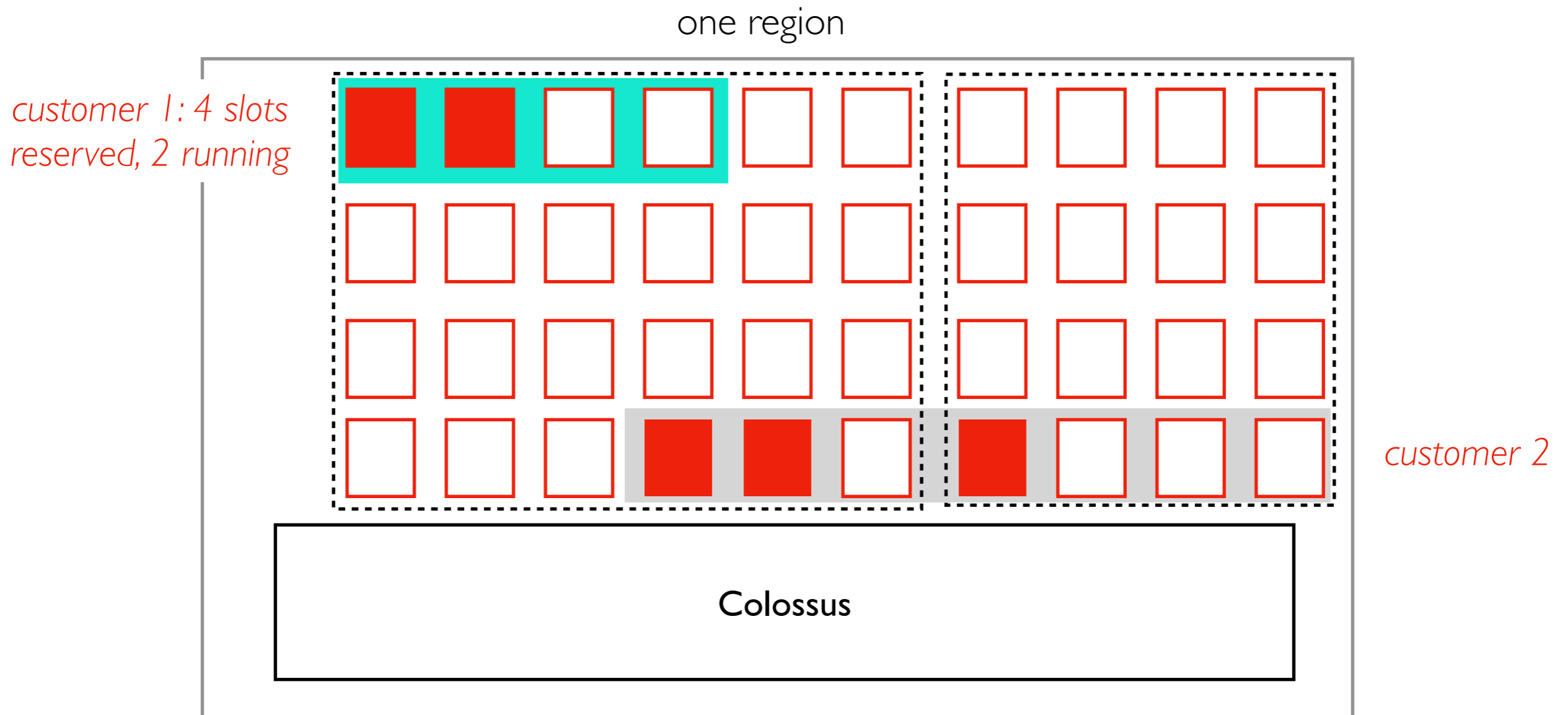

Pricing:

- pay for Colossus I/O after free tier (about \$5/TB)
- slots (compute/memory) is complementary
- use whatever is left over from capacity-based usage (up to 2000 slots!)
- **preemptible**: a task running in a slot can be interrupted (if a reservation is suddenly needed or new on-demand jobs start -- want to share capacity between these fairly)

Billing Model 2: On-Demand Pricing (I/O based)

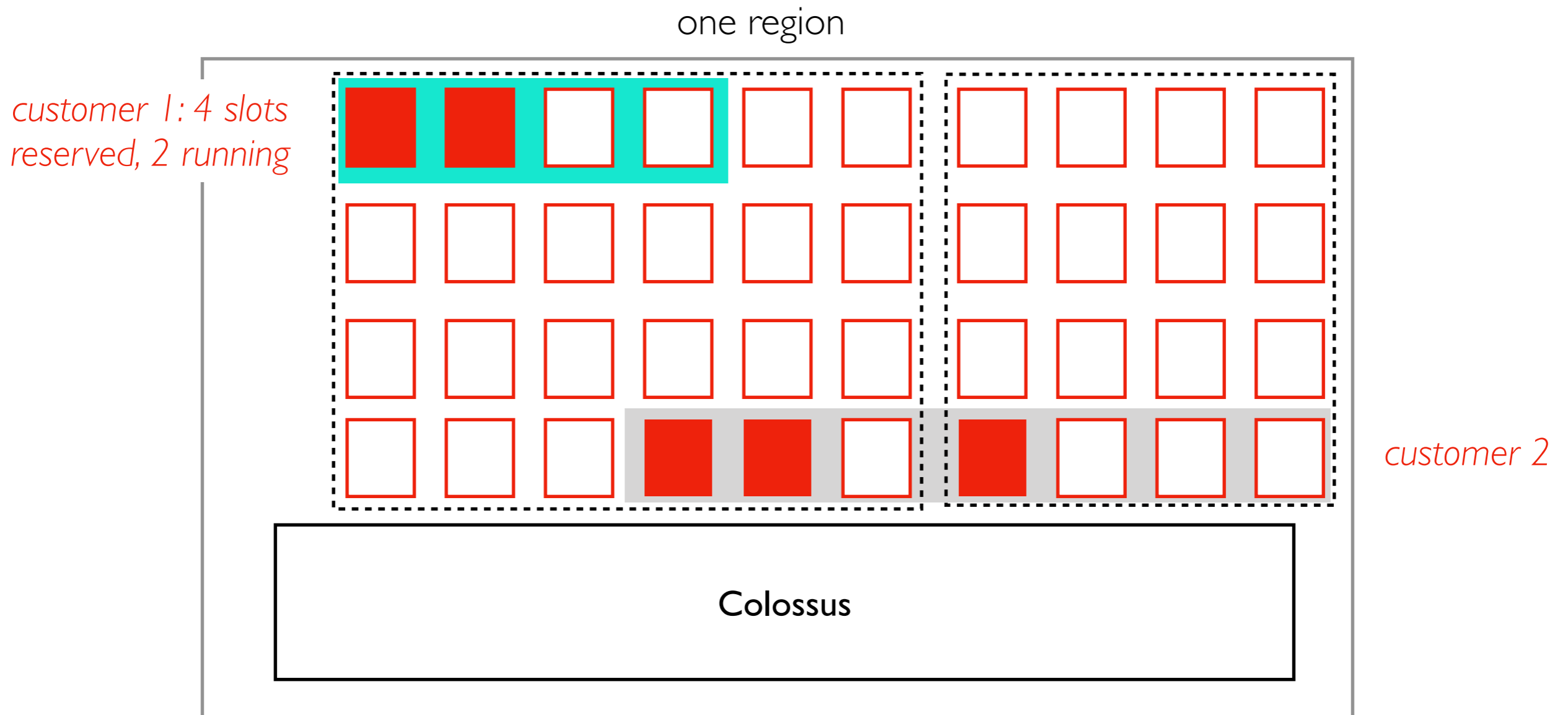





Pricing:

- pay
 - slots
 - use
 - preemptible: a task running in a slot can be interrupted (if a reservation is suddenly needed or new on-demand jobs start -- want to share capacity between these fairly)
- BigQuery tasks are atomic and idempotent so we have exactly-once semantics. Don't want interrupted and restarted tasks to cause duplicate results.** (2000 slots!)

Estimating/Capping On-Demand Costs

Filter bigquery Enter property name or value

<input type="checkbox"/>	Service	Quota	Limit	Current usage percentage ↓	Current usage	
<input type="checkbox"/>	BigQuery API	Query usage per day	209,715 MiB (204.8 GiB)	 0.26%	549 MiB	 
<input type="checkbox"/>	BigQuery API	Requests per day	Unlimited	-	25	 

Options:

- Limit per day:
<https://console.cloud.google.com/iam-admin/quotas>
- Estimate before run:
`job_config=bigquery.QueryJobConfig(dry_run=True)`
- Set max per query:
`bigquery.QueryJobConfig(maximum_bytes_billed=200*1024**2)`
- See most expensive queries:
`cs320-f21.region-us.INFORMATION_SCHEMA.JOBS_BY_PROJECT`

Demos...

Partitioning

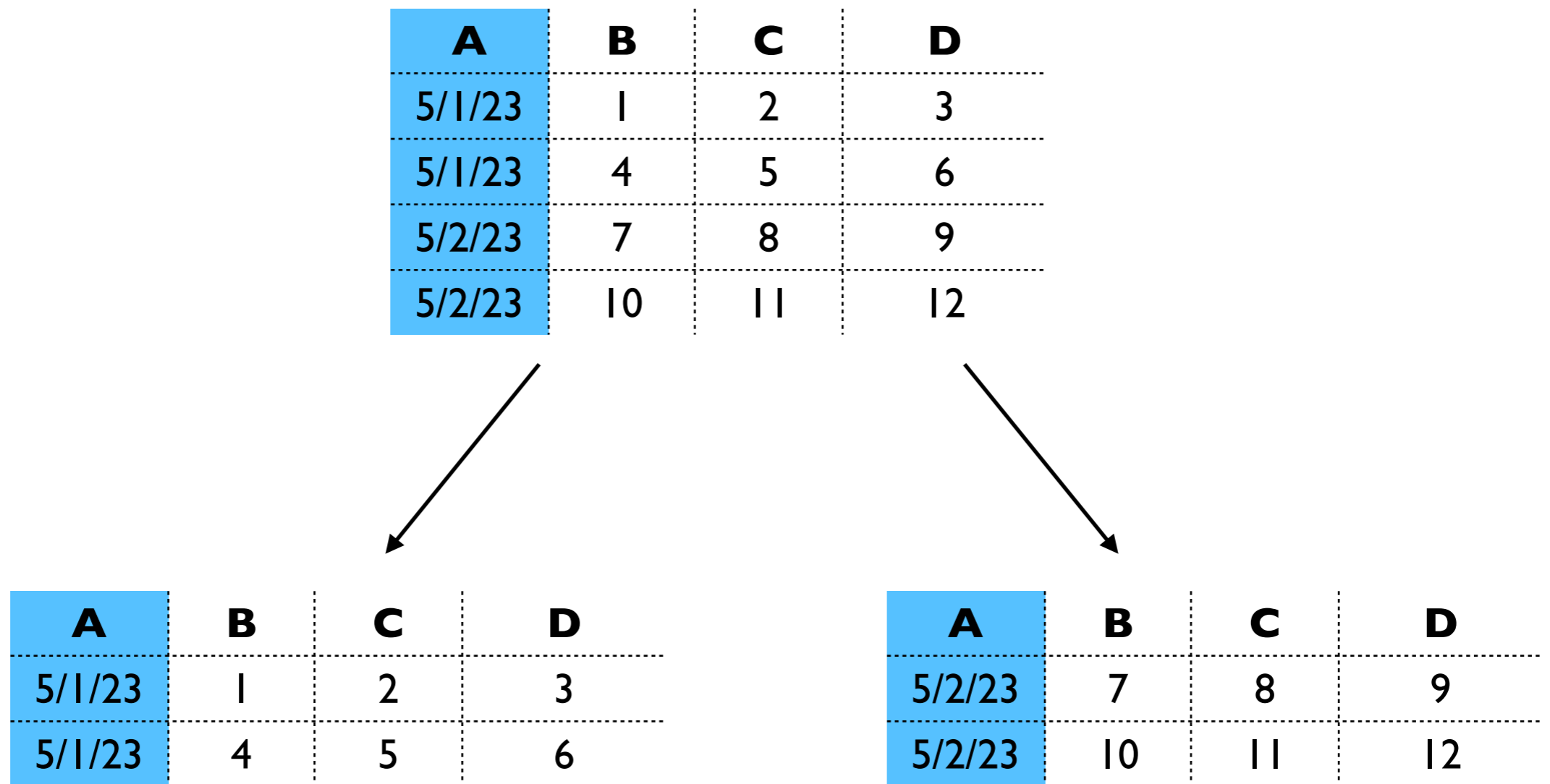

- each unique value in a partition column corresponds to a partition (basically a mini table)
- WHERE filters can limit which mini tables need to be read (saving I/O cost)
- limited options for types (e.g., ints, dates)
- only works when substantial data per partition

Clustering

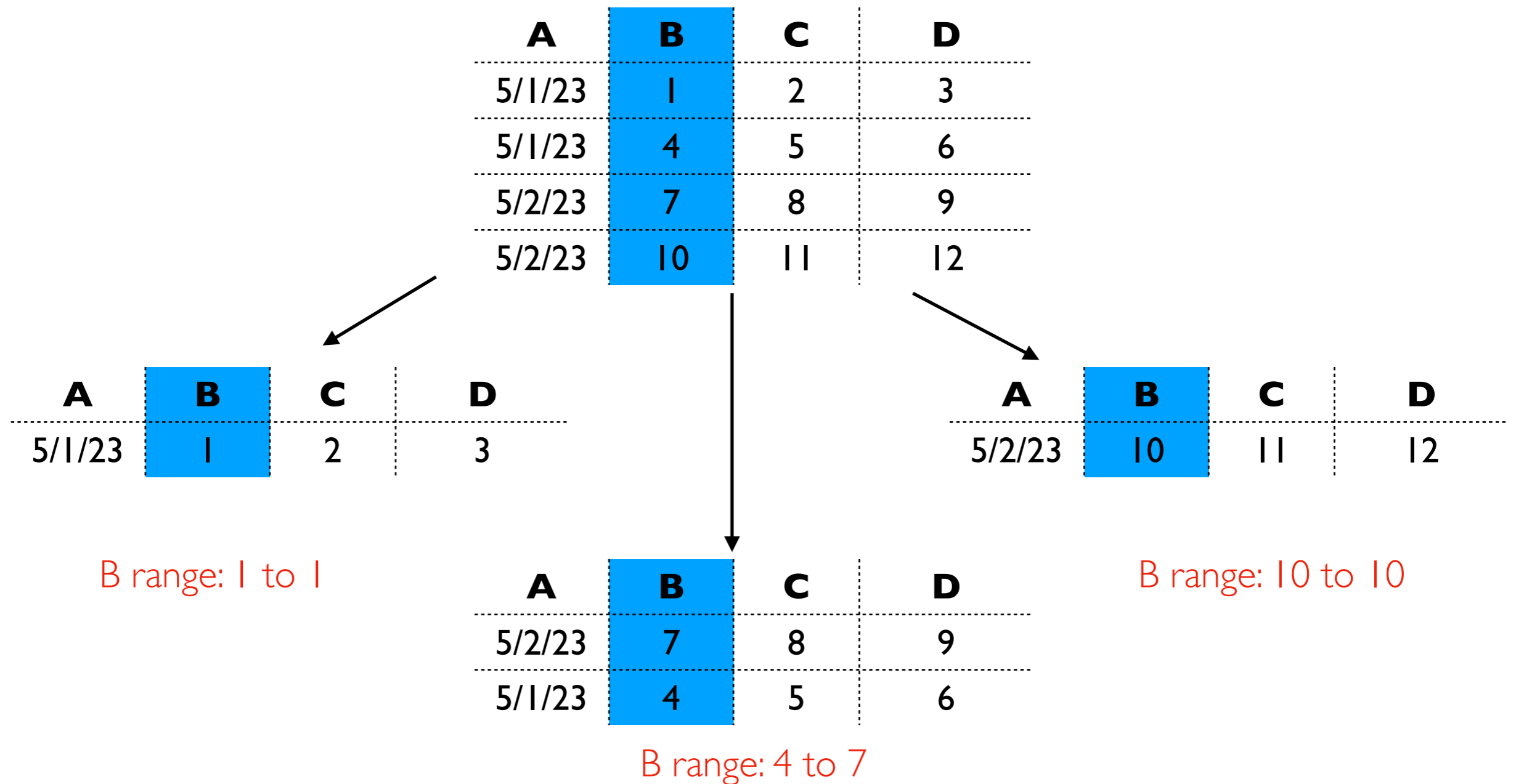

- semi sorted: sub files are non overlapping on cluster key, but no order within file
- all types, combinations of columns possible
- some queries will be cheaper because they can look at subset of files

Clustering

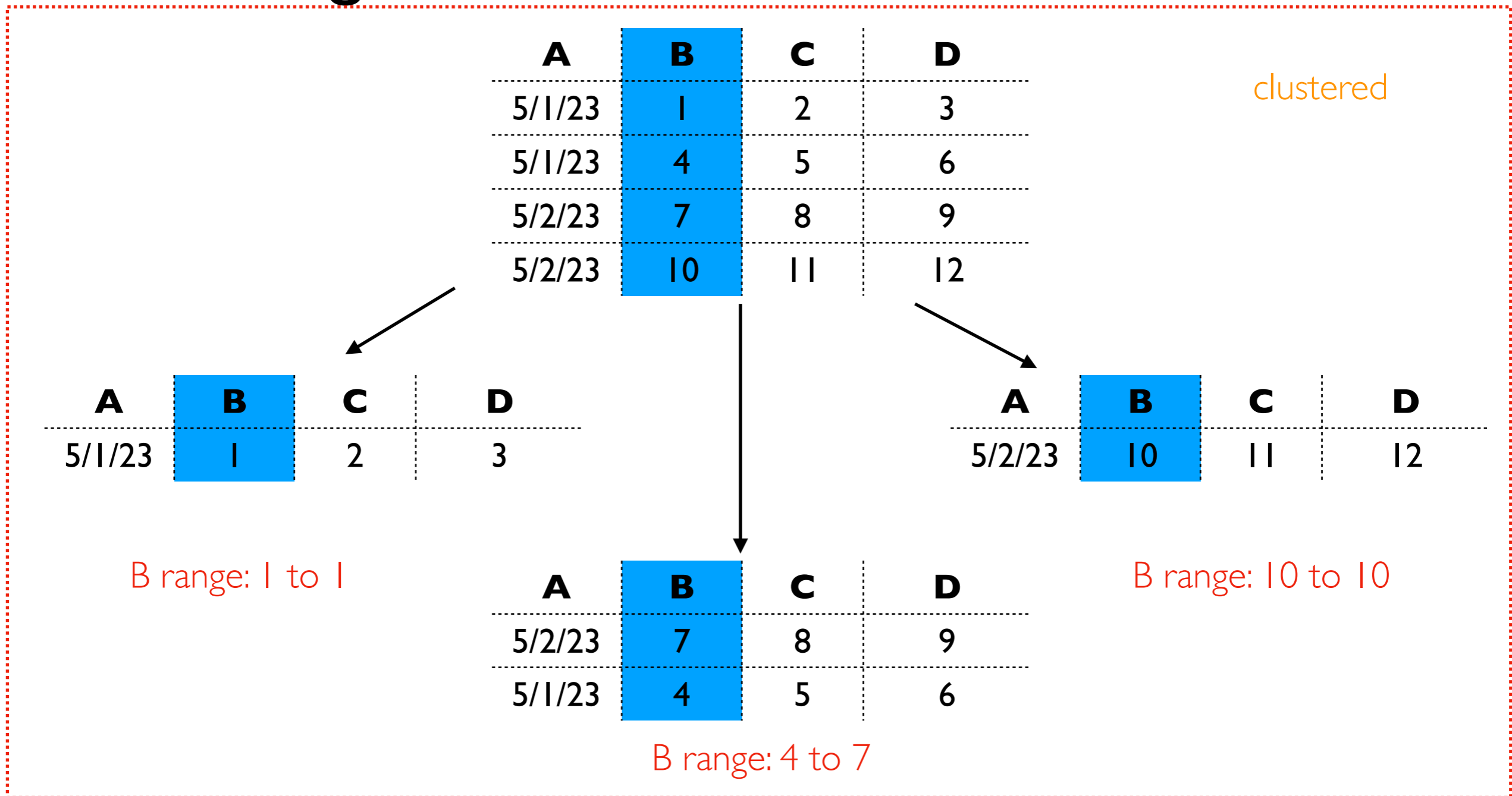

clustered

B range: 1 to 1

B range: 10 to 10

B range: 4 to 7

- some min ratio of data is clustered
- don't want few new rows to force total reorg

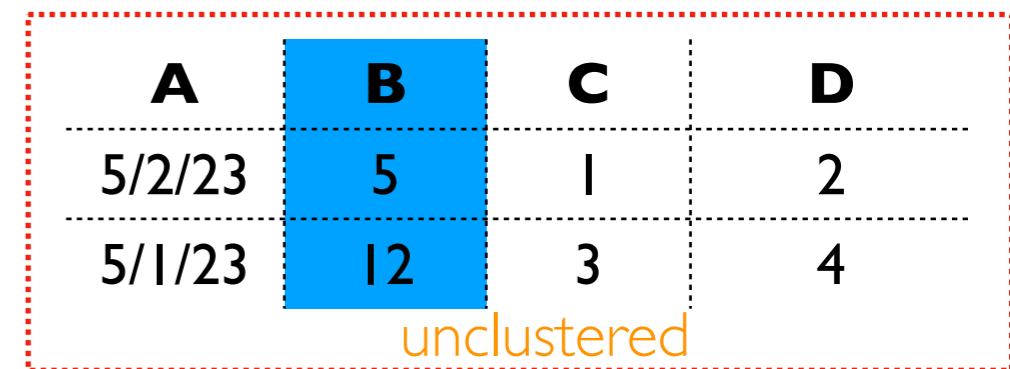

Demos